

**AVIATION TECHNICAL  
SOLUTIONS, LP**

**OPERATION AND MAINTENANCE  
MANUAL**

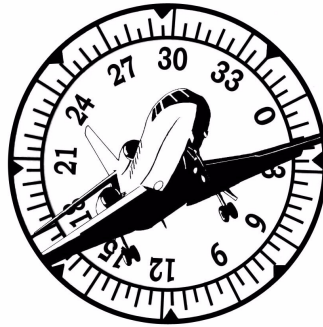

**AS-106**

**ANTI SKID DRIVE SYSTEM**

**MANUAL NUMBER 106-01**

**REVISION 6: January 3, 2010**

COPYRIGHT NOTICE  
Aviation Technical Solutions, LP  
433 Starlight Dr.  
Keller, TX 76248

## **TABLE OF CONTENTS**

SECTION I	GENERAL INFORMATION	4
1.1	INTRODUCTION	4
1.2	DESCRIPTION	4
1.3	CONTROLS AND INDICATON	5
1.4	TECHNICAL CHARACTERISTIC	7
SECTION II	PREPERATION	9
2.1	UNPACKING	9
2.2	SETUP	9
SECTION III	OPERATION	9
3.1	INSTALLATION	9
3.2	POWER UP	10
3.3	TESTING PROCEDURES	10
SECTION IV	MAINTENANCE	10
4.1	GENERAL MAINTENANCE	10
4.2	PERIODIC MAINTENANCE	10

## **LIST OF ILLUSTRATIONS**

Illustration		Page
1	Controller Box Face Layout	5
2	Motor, Adapter and Coupling	8

## **APPENDIX**

A	HawkerBeechcraft 4000
B	Falcon 10, 100, 20, 200, 50, 50EX, Late Crane Hydro-Aire
C	Falcon 900, 900B, 900C
D	Falcon 900EXEZ, 2000EXEZ
E	Falcon 7X
X	Calibration Procedure and Compliance Record

# SECTION I

## GENERAL INFORMATION

### 1.1 INTRODUCTION

This manual contains information describing the mechanical and electrical characteristics as well as operation and maintenance of the AS-106 Anti Skid Drive System (ASDS). The description of the AS-106 referenced in this manual also applies to the AS-104, the only difference being the latter does not have provision to drive nose gear wheel speed transducers. All reference to the nose gear can be ignored.

### 1.2 DESCRIPTION

The AS-106 is an electro-mechanical system that drives each wheel speed transducer simultaneously and independently on each landing gear wheel. The AS-106 consists of control circuitry, drive motors and wheel speed transducer interface adapters packaged in an easy to handle assembly. The speed is displayed in RPM on the controller. There are controls to adjust the speed of each motor independently. The AS-106 is typically used to verify brake system functionality with minimal intrusion into the aircraft. Examples of conditions requiring use of the Anti Skid Drive System include, but are not limited to:

- Replaced BCU or system component
- Performing operational checks on normally functioning brakes
- Verify operation of brake pedals and WOW switches
- Verifying operation of touchdown protection

The landing gear wheel hubcap has an integral drive coupling that engages the wheel speed transducer also known as a tach/generator. In practice, the mechanic will remove the hubcap and attach the AS-106 adapter in its place. Some applications require an adapter to be mounted to the wheel, replacing the hub cap. Other designs require an adapter that slips inside the axle. Each of the landing gear wheels will be fitted with an adapter and coupling that mates the drive motor to the aircraft wheel speed transducer. Cabling connects the motor/adapter to the remotely located control unit. After powering up, the control unit circuitry will be capable of varying and automatically adjusting the pre selected speed of each motor as the tachometer on the face of the AS-106 control unit indicates this speed in RPM. The spinning wheel speed transducer simulates a rolling aircraft by turning one, all or any combination of wheel speed transducers. The ASDS control unit can vary the speed of the motors for simulating loss of traction of one or any combination of the tires. During brake system checkouts, aircraft brake pedals may be depressed, WOW switch activated, or checks performed for high/low brake pressure indications.

# ILLUSTRATION 1 CONTROLLER BOX FACE LAYOUT

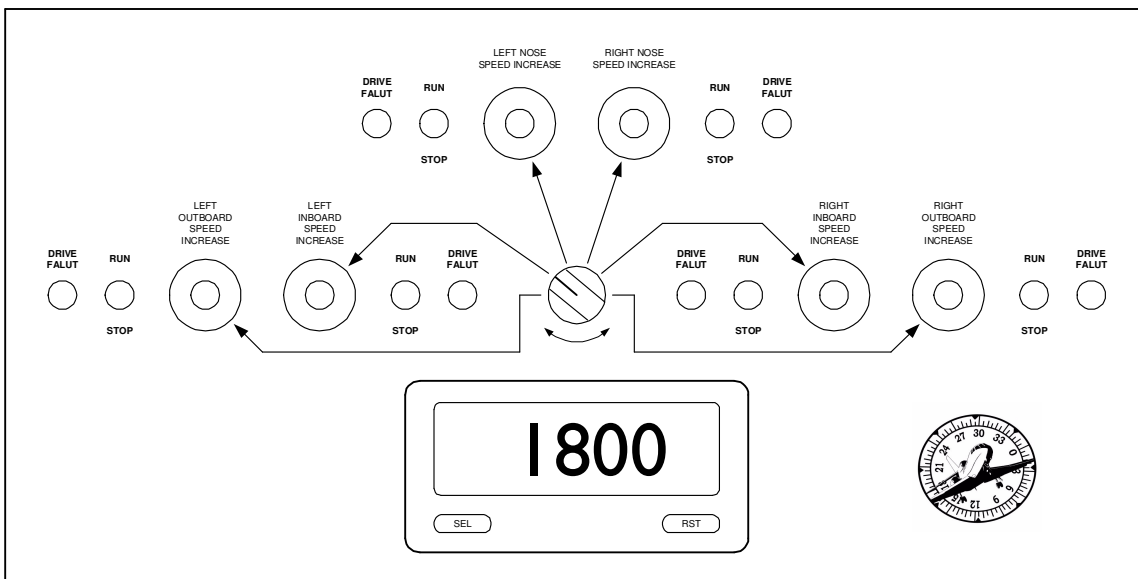

AS-106 FACE

## 1.3 CONTROLS AND INDICATION

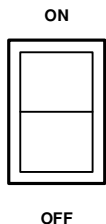

ON/OFF SWITCH

Located on the back of the ASDS control box, the ON/OFF SWITCH applies and removes AC line power to the entire AS-106 system.

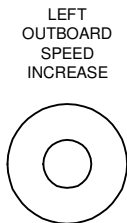

MOTOR SPEED CONTROL

Increases and decreases speed of individual drive motors.

RUN



STOP

### RUN/STOP SWITCH

Removes power from individual drive motors.

DRIVE  
FALUT



### DRIVE FAULT INDICATOR

This light alerts the operator to a fault or failure in the AS-106 drive for the wheel indicated. Some possible causes are: an incorrectly engaged drive coupling, excessively high torque required to turn the aircraft wheel speed transducer or any condition resulting in excessive current flow to the drive motor. **This light is not an indication of a fault in the aircraft anti-skid system.**

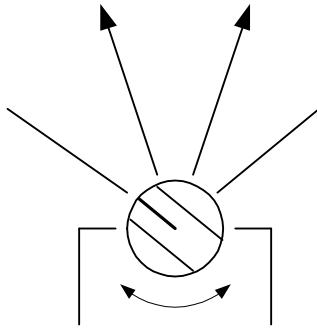

### WHEEL SELECTOR SWITCH

This is a six position switch that is used to select the drive motor to be displayed on the Digital Speed Display.



### DIGITAL SPEED DISPLAY

The Digital Speed Display indicates the speed of the selected drive motor and is expressed in RPM. The SEL and RST buttons have no user accessible functions.

## 1.4 TECHNICAL CHARACTERISTICS

### PHYSICAL DIMENSIONS:

Control Unit	10x8x5
Motor Assembly	2" dia. X 6" long

### WEIGHT:

Entire System Packed in Shipping Case	52 lb
---------------------------------------	-------

### ELECTRICAL:

Input	110-240vac, 50-60Hz
Output to motor	24vdc

### MECHANICAL:

Motor Speed Range	75 to 1800 RPM
-------------------	----------------

**ILLUSTRATION 2  
MOTOR, ADAPTER AND COUPLING**

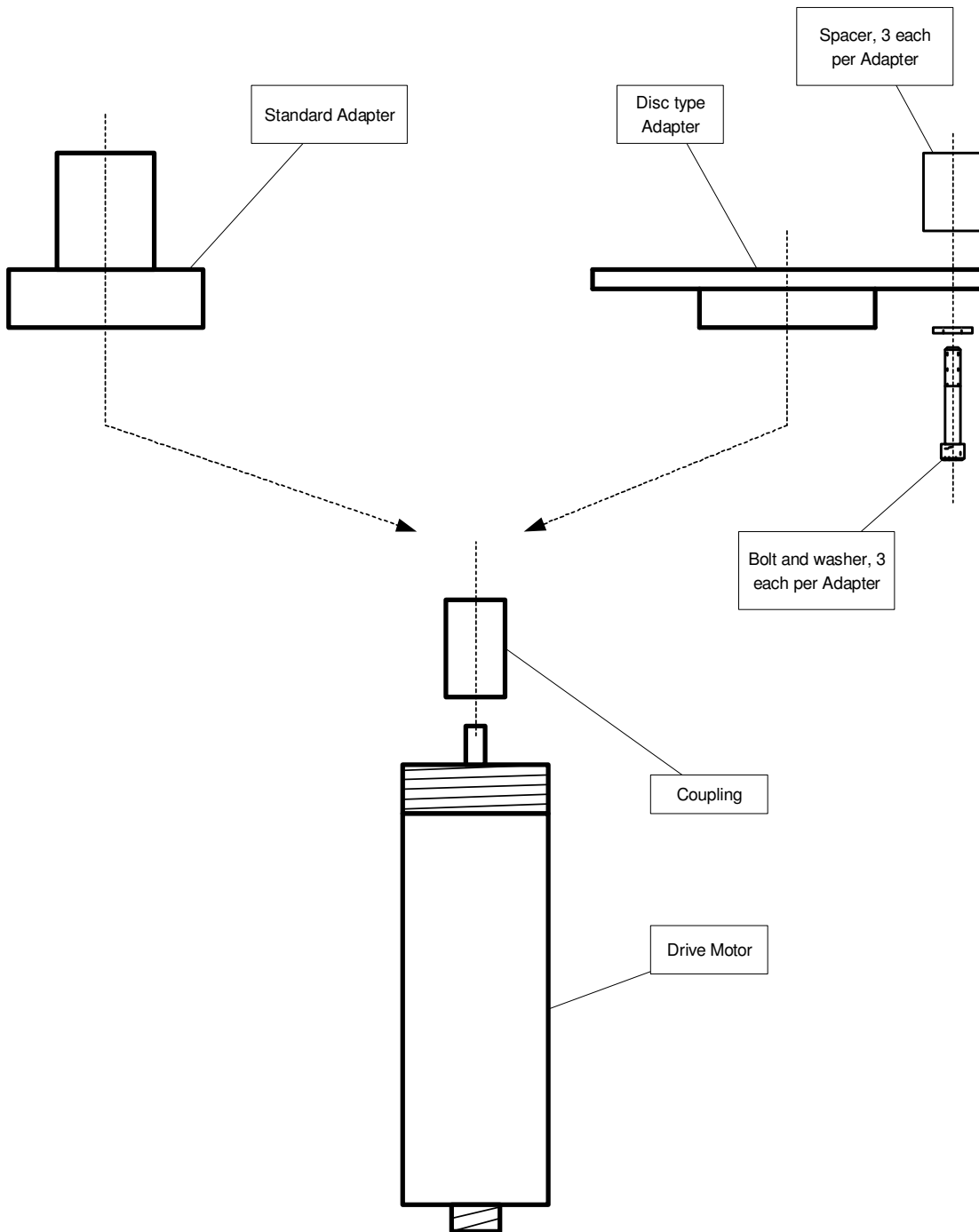

**See the Appendix for specific application**



## **SECTION II PREPARATION**

### **2.1 UNPACKING**

Carefully remove all components from the storage case and visually inspect them for signs of wear or damage.

### **2.2 SETUP**

Lay out the INTERCONNECT CABLE to each wheel paying careful attention to the direction of rotation noted on the connectors. See the direction of rotation key list below. Install the DRIVE COUPLINGS appropriate to the aircraft, secure these couplings to the motor drive shaft with the set screws. Remove the hub caps from the aircraft wheels. Install the ADAPTERS onto the DRIVE MOTORS. For some applications it may be easier to install the adapter on the wheel first. Connect the INTERCONNECT CABLE to the MOTOR DRIVE ASSEMBLIES and the CONTROLLER BOX. Ensure the POWER SWITCH and all the motor RUN/STOP SWITCHES on the CONTROLLER BOX are off. Connect the POWER CABLE to the CONTROLLER BOX and a power source (110-240vac, 50-60Hz) using an extension cord as necessary.

Direction of rotation key:

LMG OTBD = Left main gear, outboard

LMG INBD = Left main gear, inboard

RMG INBD = Right main gear, inboard

RMG OTBD = Right main gear, outboard

L NOSE = Nose gear, Left

R NOSE = Nose gear, Right

## **SECTION III OPERATION**

### **3.1 INSTALLATION**

With the ON/OFF switch OFF and all the RUN/STOP SWITCHES set to stop, install all the MOTOR DRIVE ASSEMBLIES onto the wheels in place of the hub caps. Pay careful attention to the engagement of the DRIVE COUPLING into the wheel speed transducers.

## **3.2 POWER-UP**

Select all the RUN/STOP switches to STOP and SPEED set knobs to 0 (fully counter-clockwise). Select ON with the ON/OFF switch and note the display shows 0 RPM after the display test. Select LEFT MAIN GEAR OUTBOARD with the DISPLAY SELECTOR SWITCH and increase the associated SPEED CONTROL KNOB until the desired RPM is displayed. Check that the FAULT LIGHT is not illuminated. Repeat this process with all the other gear positions. The RUN/STOP switches and SPEED CONTROL KNOBS may now be used to stop the rotation or vary the speed of individual drive motors.

## **3.3 TESTING PROCEDURES**

The AS-106 is now ready to perform testing and maintenance as required. All testing performed in this process must be in accordance with the aircraft manufacturers approved procedures. Motor duty time should be limited to 30 minutes of continuous operation followed by 1 hour cooling time.

# **SECTION IV MAINTENANCE**

## **4.1 GENERAL MAINTENANCE**

After use clean all components prior to storage. Remove any dirt, oil or moisture that may have been encountered during use. Store all components in the shipping container provided.

## **4.1 PERIODIC MAINTENANCE**

The entire AS-106 system should be returned periodically to Aviation Technical Solutions, LP for maintenance and calibration. Appendix Z contains the Calibration Procedure and Record.

# APPENDIX A

## HAWKERBEEHCRAFT 4000

The HawkerBeechcraft 4000 uses the disc adapter and standoffs with 3 each 10-32 X 2" bolts and washers. Care must be taken to insure the use of proper hardware. The 3/4" round spade type coupling is used to mate to the wheel speed transducer.

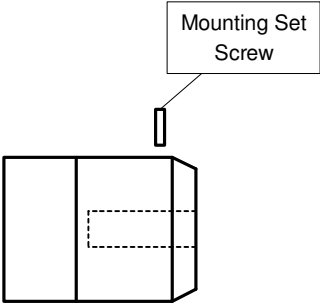
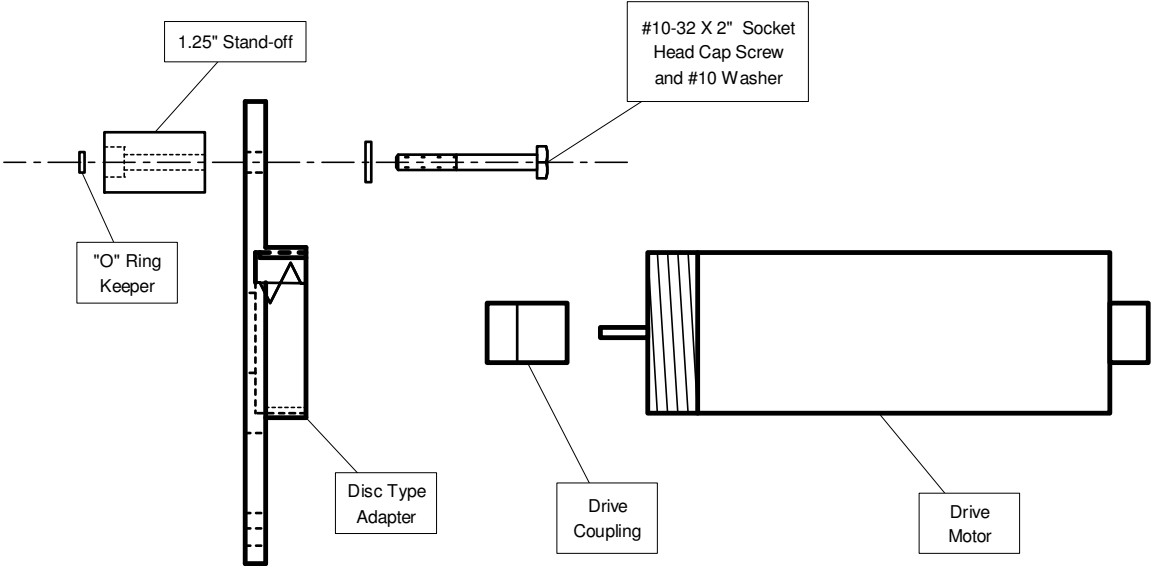

**HawkerBeechcraft  
4000 coupling**

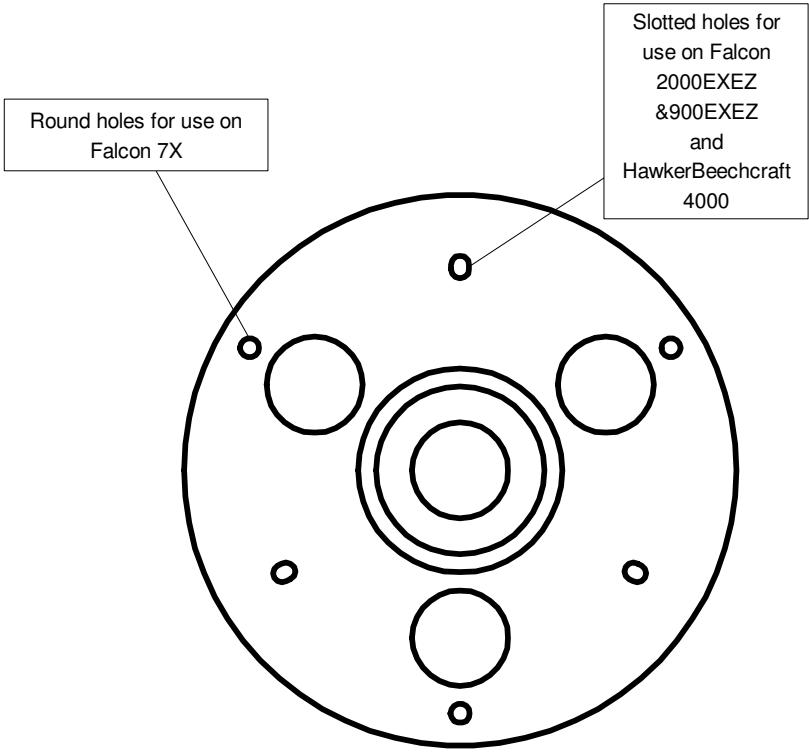

# APPENDIX B

## FALCON 10, 100, 20, 200, 50, 50EX AND LATE CRANE HYDRO-AIRE

The Falcon 10, 100, 20, 200, 50, 50EX and the late model Crane Systems use the insert type adapters and couplings as indicated in the following diagrams.

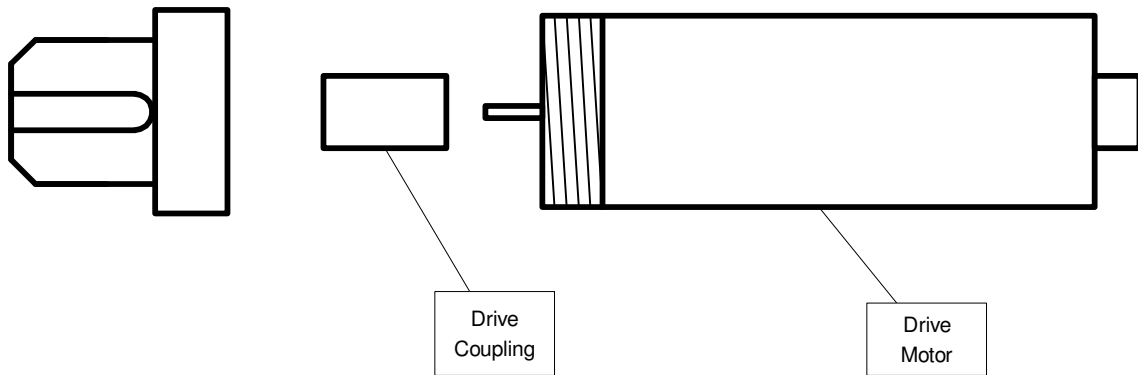

### Falcon 10, 100, 20, 200, 50, 50EX

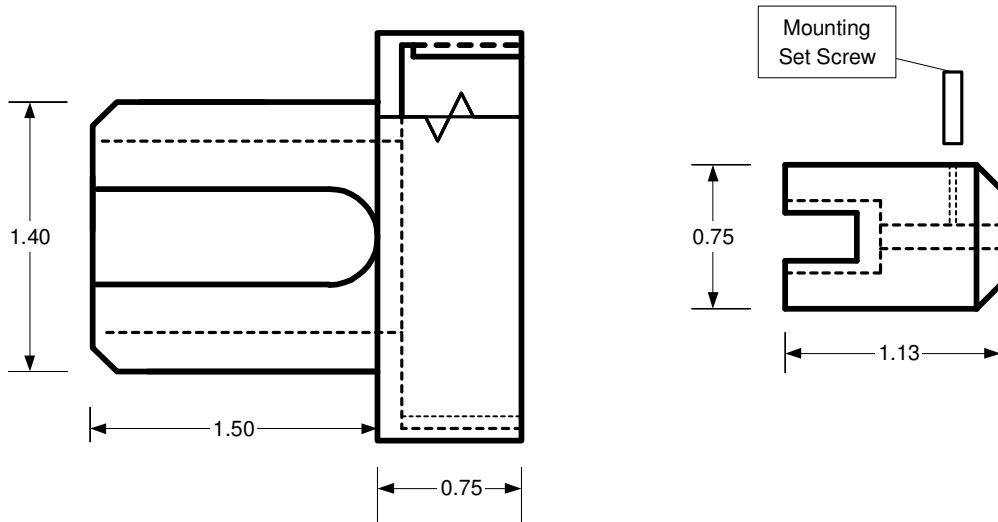

# Late Crane Hydro-Aire Systems

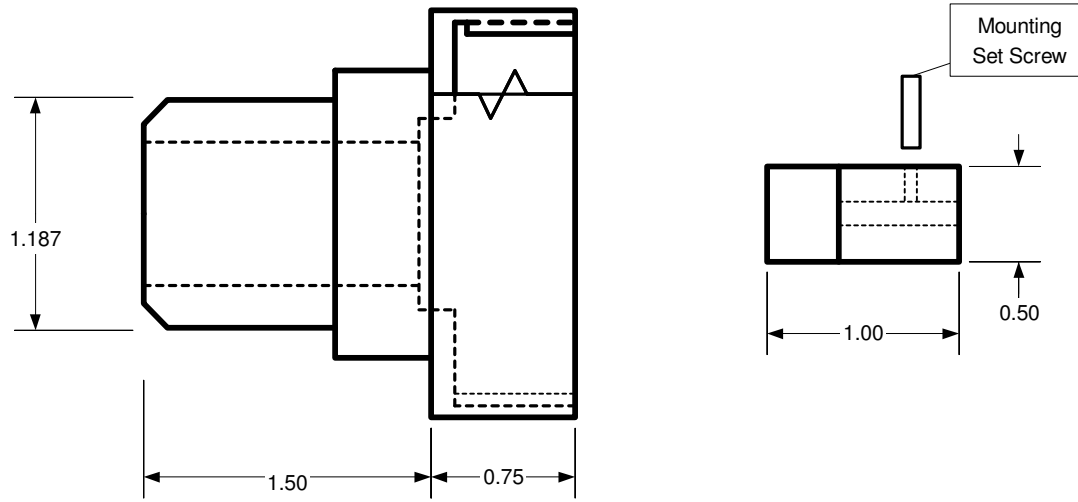

# APPENDIX C

## FALCON 900, 900B, 900C and 900EX (NOT APPLICABLE TO THE 900EXEZ)

This series of aircraft use 6 antiskid transducers, therefore, they require the use of the AS-106 drive system. Use four insert type adapters on the main gear and two on the nose gear. The main and nose gear adapters are different sizes and are not interchangeable. The 3/4" diameter round coupling is used to mate to the wheel speed transducer on the main gear. The 1/2" diameter round coupling is used on the nose gear. Both of these couplings employ soft tubing inserts that mate to the wheel speed transducers.

### Falcon 900 Main Gear

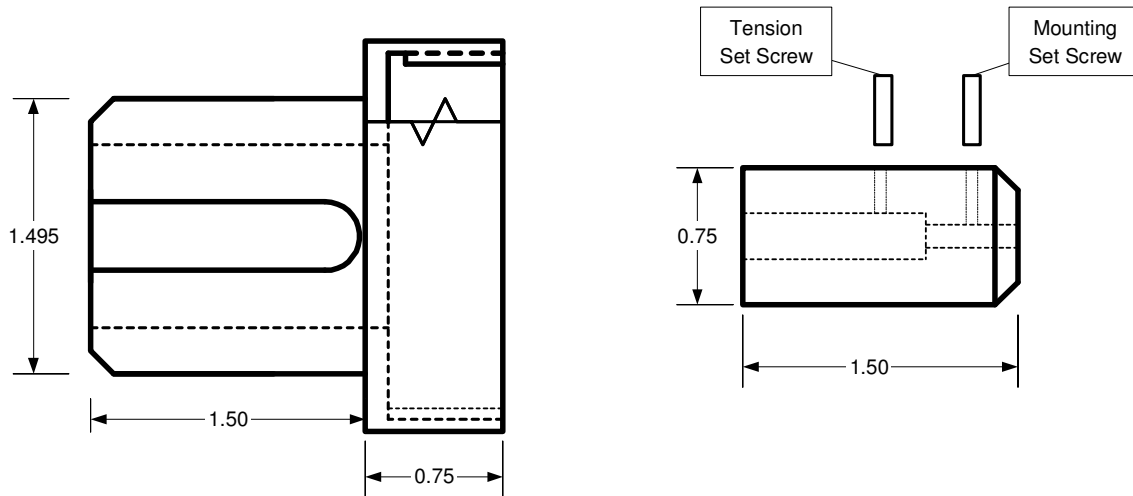

### Falcon 900 Nose Gear

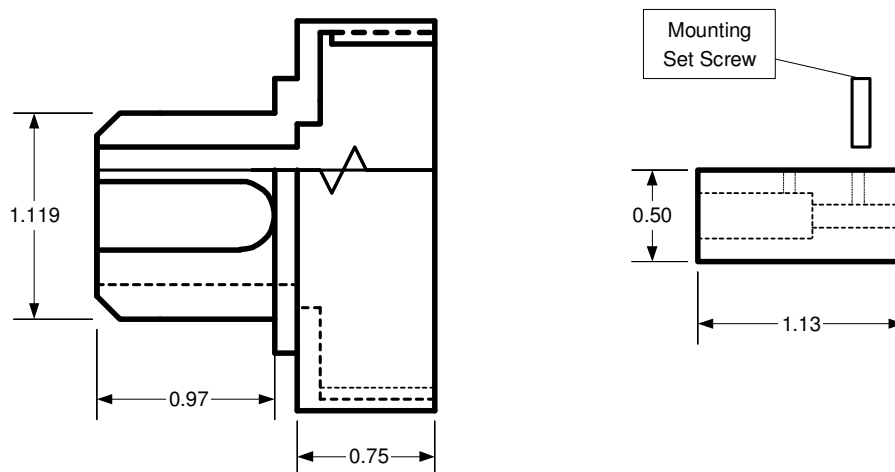

This page intentionally left blank



## APPENDIX D

### FALCON 2000EXEZ and 900EXEZ

The Falcon EXEZ aircraft use the disc adapter and standoffs with 3 each 10-24 X 2" bolts and washers. Care must be taken to insure the use of proper hardware. The 3/4" round couplings as indicated on the next page are used to mate to the wheel speed transducers.

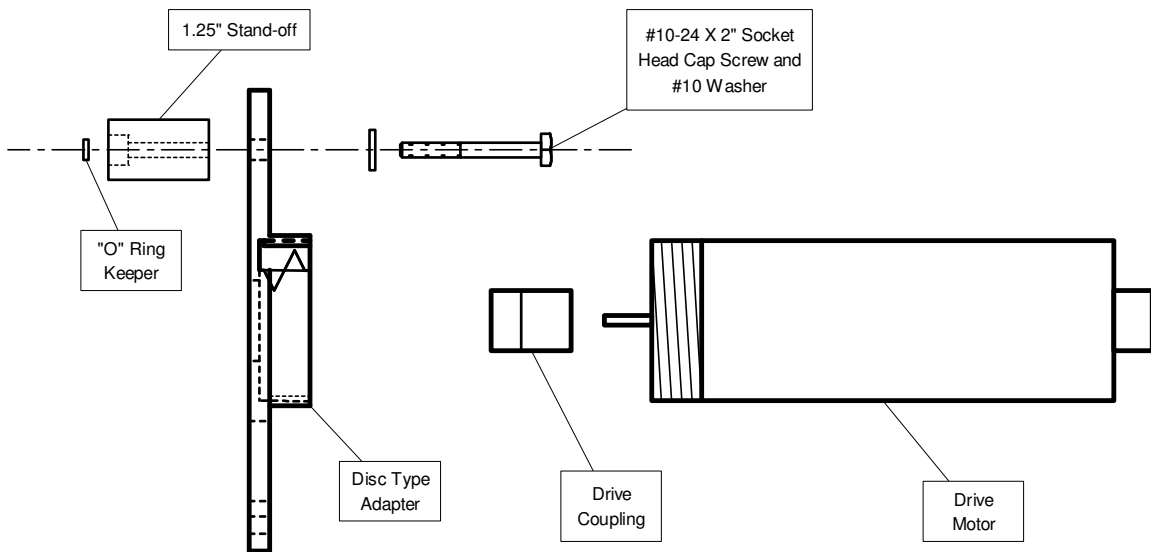

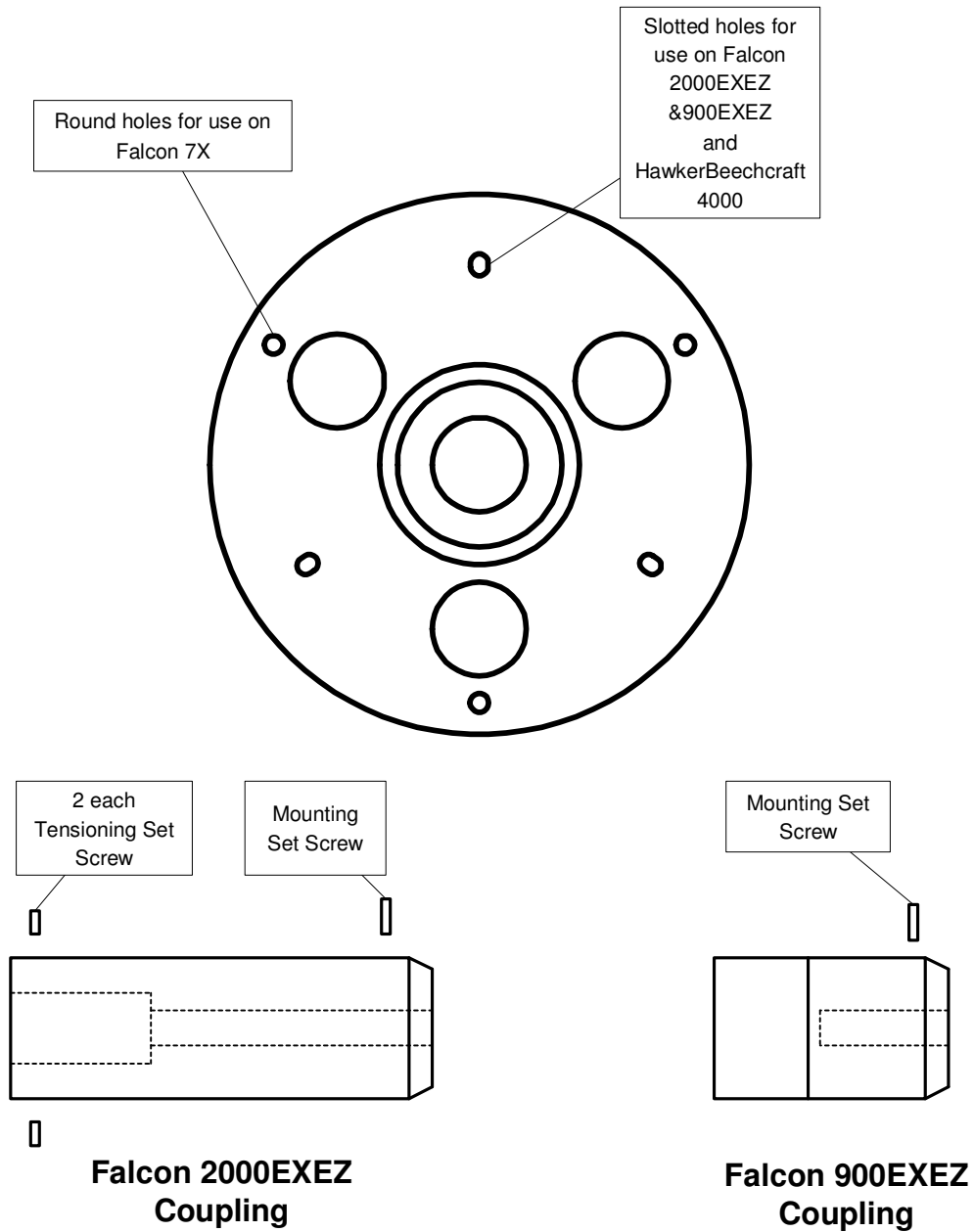

**F2000EXEZ DRIVE COUPLING ADJUSTMENT**

Test fit the Coupling, adjusting tension on the two set screws to ensure a snug fit of the soft tubing to the wheel speed transducer drive shaft. Install the Coupling onto the motor drive shaft and secure it with the single set screw. Install the motor to the Adapter and then mount the entire assembly to the wheel taking care to ensure proper engagement of the coupling to the wheel speed transducer drive shaft.

# APPENDIX E

## FALCON 7x

The Falcon 7X uses the disc adapter and standoffs with 3 each 5mm X 50mm bolts and washers. Care must be taken to insure the use of proper hardware. The 3/4" round adapter is used to mate to the tach generator.

### Falcon 7X

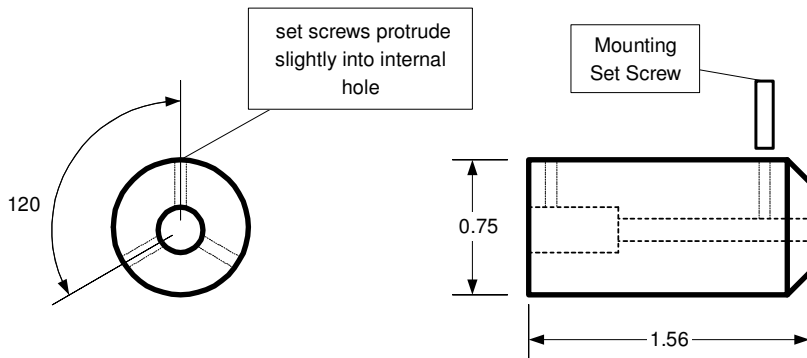
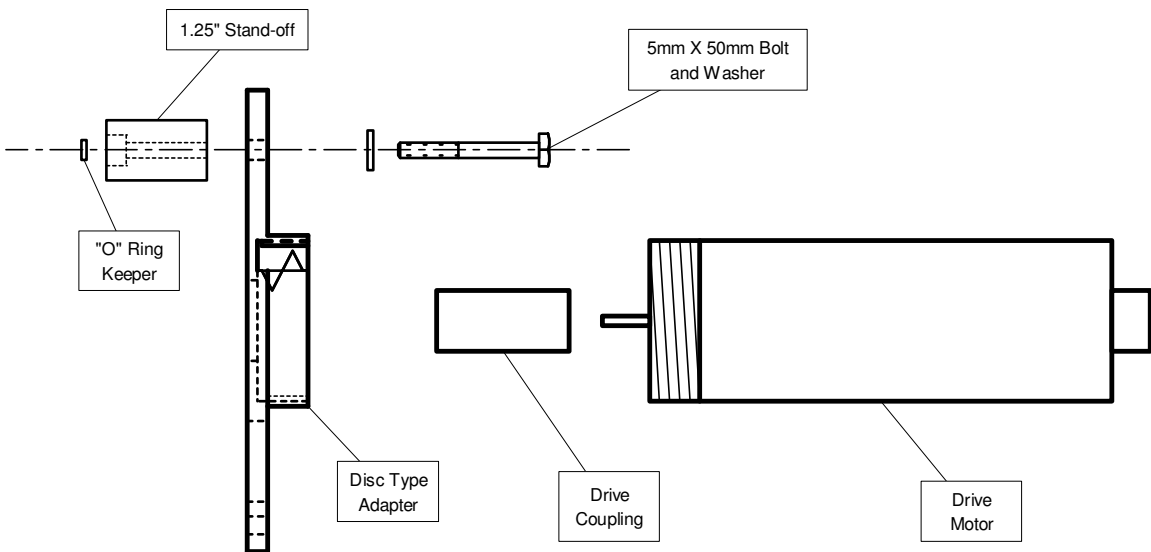

F7X P/N 6-377

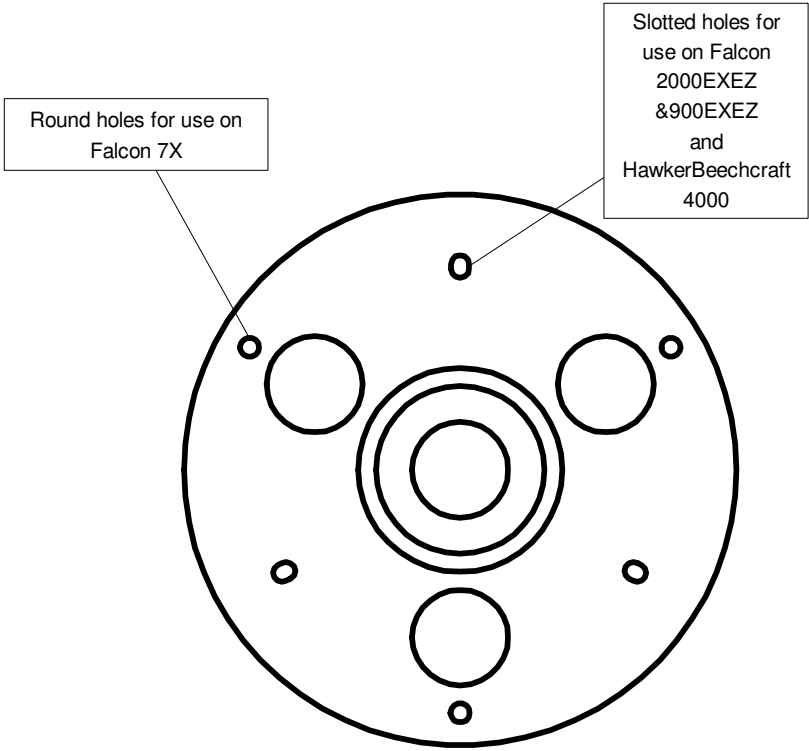

## **APPENDIX Z**

### **CALIBRATION PROCEDURE**

Equipment required:

Complete AS-100 system

Appropriate means of monitoring motor shaft output RPM.

Procedure:

1. Connect the AS-100 drive box and all the drive motors with the provided cabling, just as it would be used on an aircraft.
2. Install calibration drive coupling on the first motor.
3. Turn on the system and set the first motor to a speed of 75rpm. Compare this to the drive box display reading of 75 rpm and record the result on the calibration record.
4. Repeat step 3 at 600 rpm, 1200rpm and 1800 rpm, tolerance for each is as indicated on the **CALIBRATION RECORD**
5. Repeat steps 2 through 4 for each drive motor.

## CALIBRATION COMPLIANCE RECORD

	75 RPM	600 RPM	1200 RPM	1800 RPM
	(+/- 4 RPM)	(+/- 3 RPM)	(+/- 6 RPM)	(+/- 18 RPM)
MOTOR # 1, S/N:				
MOTOR #2, S/N:				
MOTOR #3, S/N:				
MOTOR #4, S/N:				
MOTOR #5, S/N:				
MOTOR #6, S/N:				
System P/N:				
System S/N:				
Date:				
Calibration Performed By:				